

超高速龙门3022型搅拌摩擦焊机床平面布局图

Layout Plan Of high-speed 3022 Style Friction Stir Welding Machine

超高速龙门3022型搅拌摩擦焊接机床

High-speed Gantry-Style of 3022FSW Machine

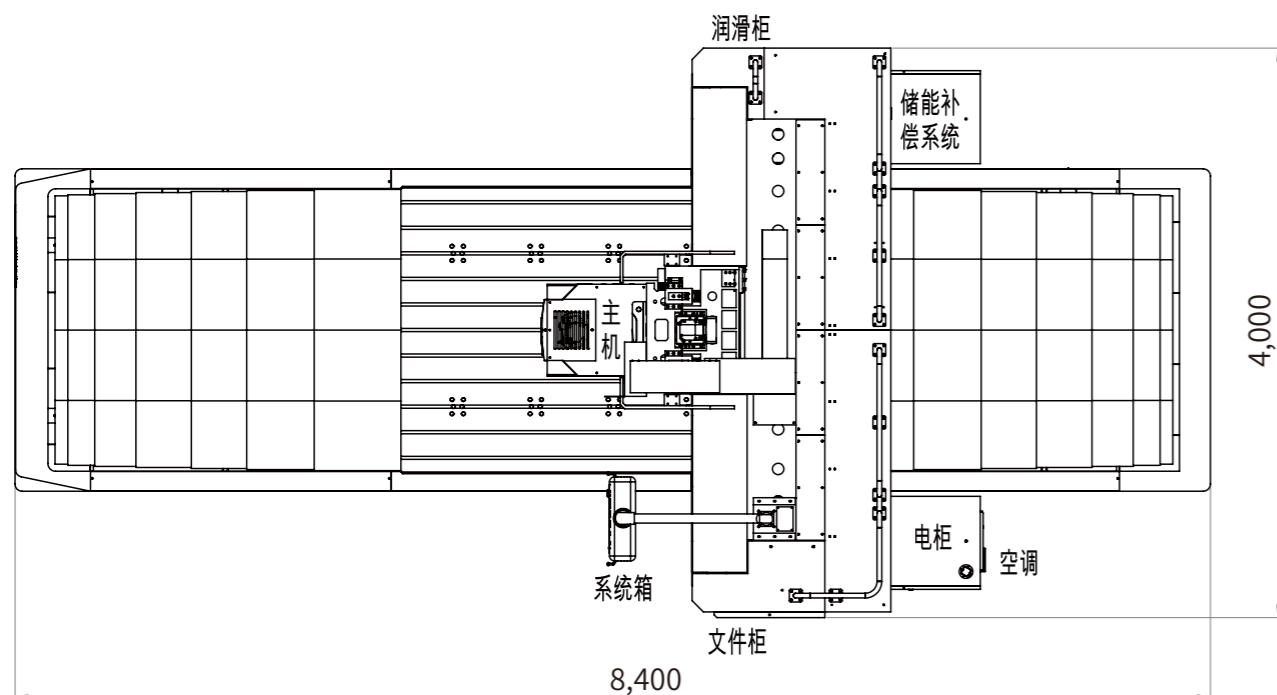

产品样本内，说明文字、图样及技术参数随技术发展而更改，不另行通知，外形尺寸以实物为准。
with technical development, the explanation, diagram and specifications are subject to change without further notice. actual machine dimensions should be taken as authentic.

北京世佳博科技集团有限公司
Beijing Sooncable Technology Group Co., Ltd

电话: +86-10-83293231
网址: www.sooncable.com
邮箱: sales@sooncable.com
北京: 北京市丰台区丰科路6号院3号楼11层
河北: 河北省廊坊市固安工业园南区兴旺东街
江苏: 江苏省昆山市陆家镇杨家村78号C幢1层
重庆: 重庆北碚区联东U谷国际企业港D8幢
广东: 广东省东莞企石镇兆丰路9号3号楼1层



2024-1版本



超高速龙门 3022 型搅拌摩擦焊接机床

秉承“做品牌，用好料”的焊接机床制造初衷，为客户提供高精度、高可靠性及高使用性价比的搅拌摩擦焊接机床。超高速龙门3022型搅拌摩擦焊接机床基于世佳博“精密搅拌摩擦焊接机床制造理念”研发的高端焊接机型。设备配备2T/3T/13T载荷及6,000/4,500/2,000RPM焊接机头，可实现铝合金单面6/8/10/25mm焊接。设备具备X轴7,000/15,000(mm/min)快速移动速度，可实现前焊后铣、一键启动、精准恒压力控制及3,000mm/min的高速焊接。同时，配备基于西门子828D并经世佳博定制开发的专用焊接系统，具有超高的控制可靠性和丰富的扩展功能。

主要特点

- 依照机床行业规范及制造标准，并结合搅拌摩擦焊接工艺特点，进行搅拌摩擦焊接机床独特设计及制造。

- 设备主体结构均采用HT300高强度精密铸造结构，经过多次热处理和时效处理。设备三轴采用两线一硬结构，XY轴采用P级滚柱线轨，Z轴采用进口复合贴塑硬轨并经过淬火。基于以上配置和工艺控制，设备整体具有较高的刚性、稳定性和良好的抗震性能；

- 机床为5轴数控，可实现“五轴联动”焊接功能；各运动轴均由西门子原装进口独立交流伺服电机驱动，可实现高运行稳定性；

- 设备配备2T/3T/13T载荷及6,000/4,500/2,000RPM焊接机头，可实现铝合金单面6/10/25mm焊接。可实现前焊后铣、一键启动、精准恒压力控制及3,000 mm/min的高速焊接；

- 实行“交钥匙”工程服务。在机床交付的同时，提供目标产品全套工艺资料，确保机床交付与产品生产无缝对接；

- 机床拥有功能强大的可选及升级配置，轻松提升焊接机床使用性能并最大化投入产出比；可实现无人化及数字化智能焊接加工；

- 机床外防护采用全新工业设计理念，在满足工业安全要求的前提下，结合现代简约风格，给人以美的享受。

关键件配置

名称	品牌	属地
● HT300精密铸造床身	● 世佳博	● 中国云南
● 主轴电机	● 西门子	● 德国
● 四轴伺服电机	● 西门子	● 德国
● 焊接主轴	● 世佳博	● 台湾
● 减速机	● 精 锐	● 台湾
● C3级滚珠丝杠	● THK	● 日本
● XY轴P级滚柱导轨	● THK	● 日本
● Z轴复合贴塑硬轨	● 世佳博	● 西班牙
● 电气	● 施耐德	● 法国

High-speed Gantry-Style of 3022 FSW Machine

Beijing Sooncable Technology Development Com., Ltd (Sooncable) make up our mind to manufacture high precision, high reliable and high cost performance Friction Stir Welding (FSW) machine for our clients. High-speed Gantry-Style of 3022 FSW Machine is equipped with2T (6,000RPM)/3T (4,500RPM)/13T (2,000RPM) welding spindle and possesses the capacity of Al-alloy for one side within 6/10/25mm. The rapid moving speed of XAxis is up to7,000/15,000(mm/min), which can realize such functions as front welding and rear milling system, one key start, accurate constant pressure control system and efficient welding speed of 3,000mm/min. Besides, it is equipped with a special FSW system based on Siemens 828D Control System and customized by Sooncable FSW team, which can realize ultra-high control reliability and rich expansion functions.

Main Features

- The FSW Machine is specially developed and built for Friction Stir Welding Process, which based on the National Specifications and Standards of precise FSW Machine.

- The main structure of the equipment adopts HT300 high strength precision casting structure, which has been heat treated and aged for many times. The three-axis adopts two-wire and one-hard structure, the XY-axis adopts p-class roller track, and the z-axis adopts imported composite hard track and quenched. Based on the above configuration and process control, the overall equipment has high rigidity, stability and good seismic performance.

- The FSW Machine has 5-axis and can achieve 4 axes coordinated welding control. Each motion axis is driven by an Siemens AC Servo Motor for nice stability of continuous long term running.

- The equipment is equipped with 2T/3T/13Tload and 6000/4,500/2,000RPM welding head, which can realize single-side 6/10/25mm welding of aluminum alloy.It can realize pre-welding and post-milling, one-key start, accurate constant pressure control and 3,000mm /min high-speed welding;

- Technical trainings and welding trials based on FSW process is also served as key part of “Turn-key” project along with the machine delivery.

- Great optional configurationrealizing automatically welding, thus increasing annual work efficiency.

- The machine reflects the development trend of manufacturing industrial, i.e. environment-friendly automatic, flexible, high efficient and function composite, making your enjoying its working environment.

Key Attachments

Description	Outsourcing component
● Lathe bed	● Customized, China
● Main axis motor	● Siemens, Germany
● Servo motor	● Siemens, Germany
● Main axle	● Customized, Taiwan
● Reducers	● Apex, Taiwan
● C3-level ball screws	● THK
● P-level roller guide	● THK
● Hard Rail	● Spain
● Electric control	● Schneider, France

主要技术参数

项 目	Description	Unit	SCB-LM3022-2D-2/3/6T		
床身材质	Bed material	/	HT300		
机床结构	Machine tool structure	/	两线一硬（Z轴硬轨）		
工作台尺寸	Work-piece size	mm	3,000×2,000		
各轴最大行程	Each axial travel	mm	3,000×2,000×600		
Z向焊接空间	Max. welding space	mm	600/700/800		
龙门跨距	LM span	mm	2,200		
主轴顶锻力	Max. Z-axis down forth	T	2	3	6
最大铝合金焊接厚度	Max. welding thickness	mm	6	10/16	12/16
最大铜合金焊接厚度	Max. welding thickness	mm	/	3	6
焊接主轴最高转速	Max. spindle speed	r/min	4,000/6,000	4,500	2,000
X/Y/Z轴快移速度	X axial Y axial Z axial	mm/min	15,000/10,000/4,500		7,000 / 4,000 /2,000
X/Y/Z轴定位精度	X axial Y axial Z axial	mm/1,000mm	0.015 / 0.015 / 0.015		
X/Y/Z重复定位精度	X axial Y axial Z axial	mm	0.01		
T型槽工作尺寸	T-groove specification	mm	22×11×180		
搅拌头夹持柄直径	Holder diameter of Tool	mm	20		
刀柄规格	Handle specificationsT	—	BT50		
数控系统	Control System	—	828D/840Dsl		
主轴倾角	Spindle inclination	°	±5		
C轴行程(选配)	C axis travel	°	N×360		
机床主电机功率	Main motor power	kw	12	12/22	39
机床电力总负荷	Total power	kw	30	30/42	60
机床尺寸	Machine size	mm	8,400×4,000×4,250/4,350/4,450		
机床重量	Total weight	kg	22,880	23,200	24,360

标准配置及功能

功能

- 急速气冷系统

- 电控系统空调系统

- 搅拌头寿命监控系统

- 焊接过程参数记录系统

- 断针检测

可选配置及功能

功能

- 点触式对刀

- DNC管理系统

- 前导滚轮系统

- 飞边铣削系统

- 恒压力控制系统

- 二维码扫描系统

- 焊接机头自适应平衡系统

功能描述

- 5分钟内气雾温度可达3°

- 电控系统恒温恒湿

- 拌头寿命实时监测

- 焊接过程参数记录及调取

- 焊前判定搅拌针是否断裂

功能描述

- 实现一键对刀功能

- 焊接数据DNC并网及智能控制

- 焊前压紧、回程矫形

- 实现前焊后铣功能

- 焊接过程恒压力控制

- 生成数据库文件并存储

- 焊接匙孔消除

Main Specifications

项 目	Description	Unit	SCB-LM3022-2D-2/3/6T		
床身材质	Bed material	/	HT300		
机床结构	Machine tool structure	/	两线一硬（Z轴硬轨）		
工作台尺寸	Work-piece size	mm	3,000×2,000		
各轴最大行程	Each axial travel	mm	3,000×2,000×600		
Z向焊接空间	Max. welding space	mm	600/700/800		
龙门跨距	LM span	mm	2,200		
主轴顶锻力	Max. Z-axis down forth	T	2	3	6
最大铝合金焊接厚度	Max. welding thickness	mm	6	10/16	12/16
最大铜合金焊接厚度	Max. welding thickness	mm	/	3	6
焊接主轴最高转速	Max. spindle speed	r/min	4,000/6,000	4,500	2,000
X/Y/Z轴快移速度	X axial Y axial Z axial	mm/min	15,000/10,000/4,500		7,000 / 4,000 /2,000
X/Y/Z轴定位精度	X axial Y axial Z axial	mm/1,000mm	0.015 / 0.015 / 0.015		
X/Y/Z重复定位精度	X axial Y axial Z axial	mm	0.01		
T型槽工作尺寸	T-groove specification	mm	22×11×180		
搅拌头夹持柄直径	Holder diameter of Tool	mm	20		
刀柄规格	Handle specificationsT	—	BT50		
数控系统	Control System	—	828D/840Dsl		
主轴倾角	Spindle inclination	°	±5		
C轴行程(选配)	C axis travel	°	N×360		
机床主电机功率	Main motor power	kw	12	12/22	39
机床电力总负荷	Total power	kw	30	30/42	60
机床尺寸	Machine size	mm	8,400×4,000×4,250/4,350/4,450		
机床重量	Total weight	kg	22,880	23,200	24,360

Optional Attachments

Function	Description
● Rapid air cooling Device	● Mist TEMP can reach 3 ° in 5mins
● Air Condition for ECC	● Temperature controlling of ECC
● Life Monitoring System	● Monitoring lifetime of FSW tool
● Parameters Recording System	● Recording & copying manually
● Broken needle detection	● Fracture judgment of tool needle

Optional Attachments

Function	Description
● Point contact tool setting	● Press the key to complete tool setting
● DNC function System	● Monitoring, controlling on line
● Scroll System marching in front	● Compact & distortion rectification
● Flash milling system	● High-speed welding environment
● Constant Force Control system	● Constant down force output
● QR code scanning system	● Generate and store database files
● Spindle Responsive System	● Eliminate FSW keyhole